

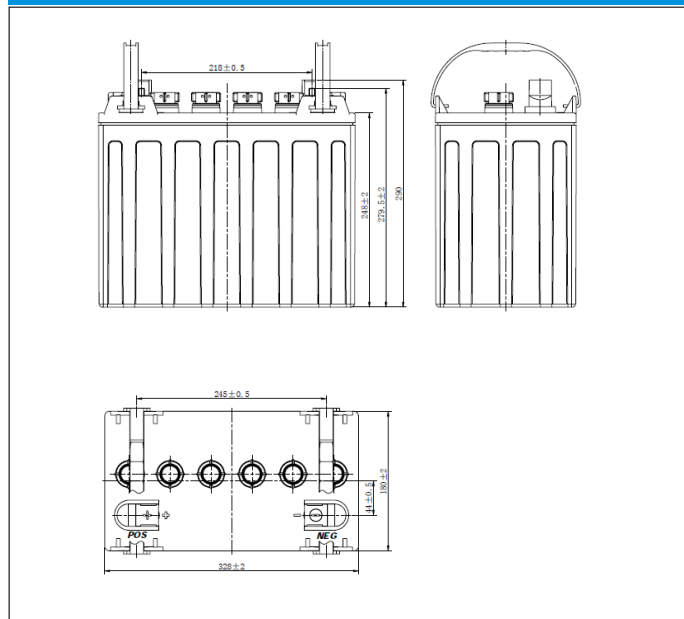

Dimensions (mm)



Physical Specification (mm)

Nominal Voltage		12V
Nominal Capacity(20HR)		140Ah
Nominal Capacity(5HR)		120Ah
Dimension	Length	328 ± 2mm(12.91inches)
	Width	180 ± 2mm(7.09inches)
	Container Height	248 ± 2mm(9.76inches)
	Total Height(with Terminal)	279.5 ± 2mm(11.00inches)
Dry Weight		Approx 28.6Kg(63.1lbs)
Wet Weight		Approx 40.1Kg(88.4lbs)
Standard Terminal		DT-M8(A)
Plate type		tubular plate
Electrolyte type		Acid (flooded)
Case		Cool Gray8C-Material
Cover		Cool Gray8C-Material
Handle		Cool Gray8C-Material

Standard Terminal (mm)

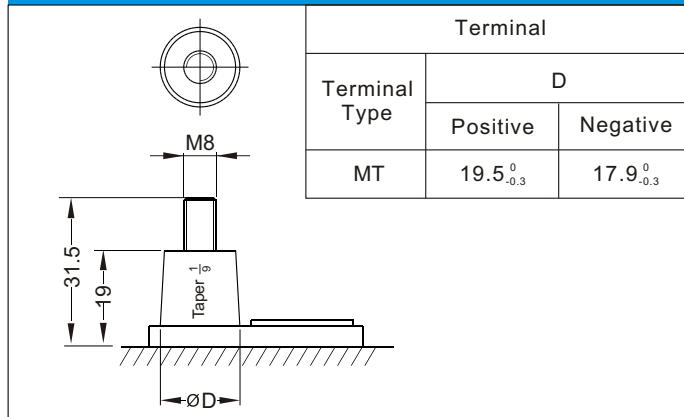

Electrical Specification

Rated Capacity	20 hour rate(7.0A)	140Ah
	5 hour rate(24A)	120Ah
Reserve Capacity	25Amps	270min

Cycle life in relation to depth of discharge

