



LEOCH BATTERY

AGM-B21 (12V40Ah)



Dimensions (mm)

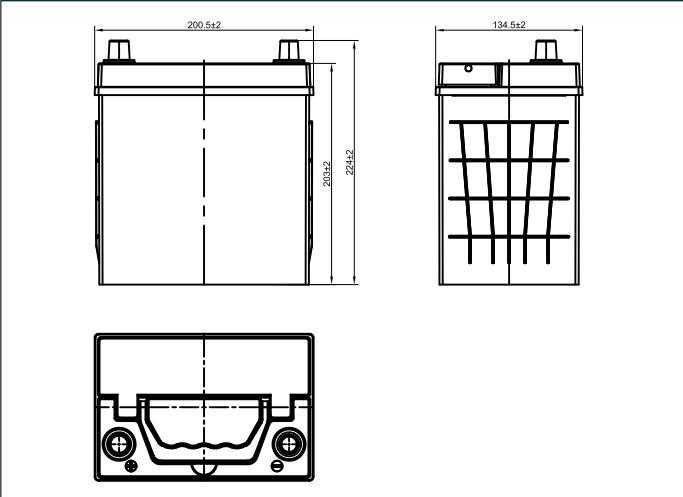

Physical Specification (mm)

Nominal Voltage		12V
Nominal Capacity(20HR)		40Ah
Dimension	Length	200.5±2mm(7.89inches)
	Width	134.5±2mm(5.30inches)
	Container Height	203±2mm(7.99inches)
	Total Height(with Terminal)	224±2mm(8.82inches)
Weight		Approx 12.5±0.5Kg(27.56lbs)
Standard Terminal		1
Cell layout		1
Hold-Down		B0
Cell plate qty		/
Case		Black-PP Material
Cover		Black-PP Material
Handle		Black-PP Material

Electrical Specification

Rated Capacity	20 hour rate(2.0A)	40Ah
Reserve Capacity	61min	
Cold Cranking Performance Amps@0°F(-18°C)	330A	

Standard Terminal (mm)

Terminal Type	D	
	Positive	Negative
1	19.5 ⁰ _{-0.3}	17.9 ⁰ _{-0.3}

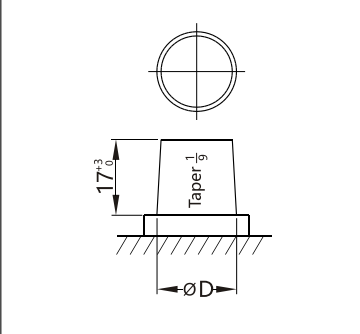

Cell Layout

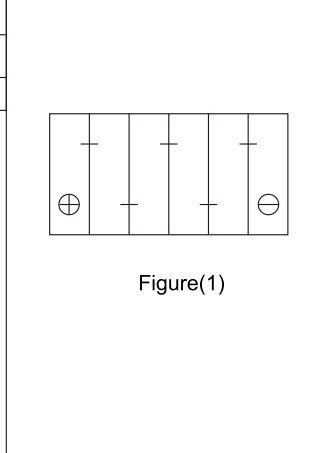

Discharge Characteristics(-18°C,0°F)

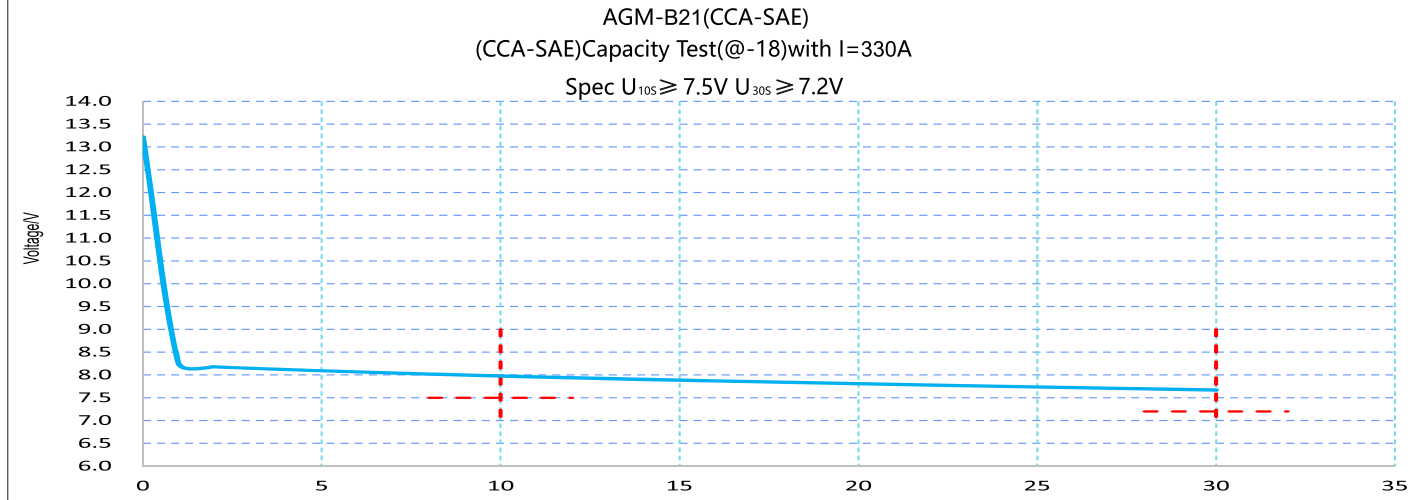

*Values are subject to variation of +/- 5% in normal manufacturing processes.
 *Technical specifications and the product line above could be changed without prior notice.