

HEAVY DUTY EFB DUAL PURPOSE BATTERY

EFB-180L (12V180Ah)



CHARACTERISTICS

Item	Specifications	
Nominal Voltage	12V	
Nominal Capacity (20HR)	180Ah	
Reserve Capacity	360min	
Cold Cranking Amps@0°F (-18°C)	1000A	
Dimension	Length	510mm (20.1inches)
	Width	222mm (8.74inches)
	Container Height	196mm (7.72inches)
	Total Height (with Terminal)	217mm (8.54inches)
Approx Weight	47.4kg (104.5lbs)	
Terminal	1	
Cell layout	4	
Hold-Down	B0	
Case	Black-PP Material	
Cover	Black-PP Material	
Handle	TS8	

APPLICATIONS

- Parking air-conditioner
- Commercial vehicle start
- Engine start

GENERAL FEATURES

- Long service life
- Super capacity reach 220Ah
- EFB paste provide long deep cycle life
- PE-glass mat separator
- Good charging acceptance because of carbon additive, can fast recharge
- Excellent start ability
- OE quality certification

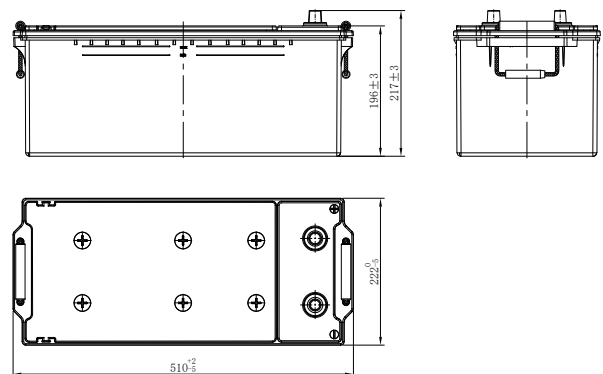
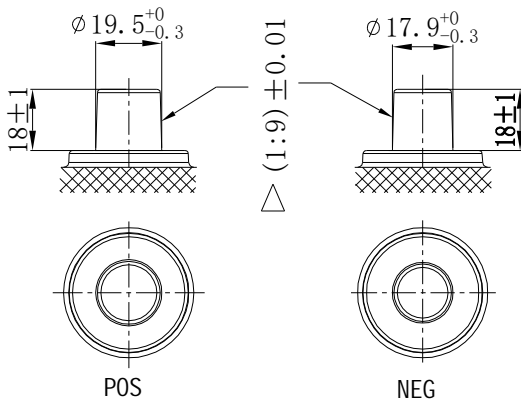

*Values are subject to variation of +/- 5% in normal manufacturing processes.

Leoch International Technology Ltd.
www.leoch.com

Leoch Batteries Pte Ltd
www.leoch.sg

Leoch Battery Corporation
www.leochamericas.com

Leoch Europe S.A.
www.leoch.eu