

EFB START-STOP BATTERY

EFB-L1 (12V50Ah)



CHARACTERISTICS

Item	Specifications	
Nominal Voltage	12V	
Nominal Capacity (20HR)	50Ah	
Reserve Capacity	80min	
Cold Cranking Amps@0°F (-18°C)	540A	
Dimension	Length	207mm (8.15inches)
	Width	175mm (6.89inches)
	Container Height	190mm (7.48inches)
	Total Height (with Terminal)	190mm (7.48inches)
Approx Weight	14.6kg (32.2lbs)	
Terminal	1	
Cell layout	0	
Hold-Down	B13	
Case	Black-PP Material	
Cover	Black-PP Material	
Handle	TS2	

APPLICATIONS

- Car with start-stop system
- EV/HEV
- Engine start

GENERAL FEATURES

- High capacity and high CCA
- 2x Faster Charge Acceptance than conventional starter batteries
- 2x Higher Cycle Life than conventional starter batteries
- Strong alloy grids for rugged durability and improved tolerance in extreme temperature conditions
- OE quality certification

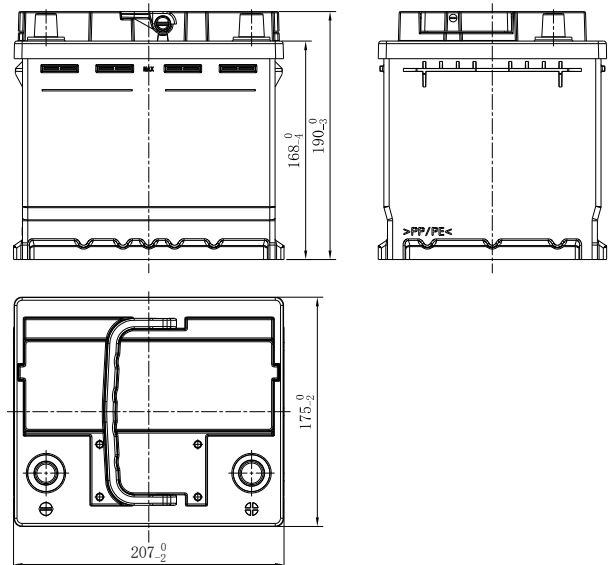
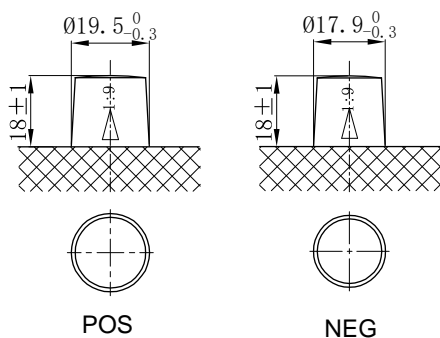

*Values are subject to variation of +/- 5% in normal manufacturing processes.

Leoch International Technology Ltd.
www.leoch.com

Leoch Batteries Pte Ltd
www.leoch.sg

Leoch Battery Corporation
www.leochamericas.com

Leoch Europe S.A.
www.leoch.eu