

# FLOODED BATTERY

31AT-700 (12V90Ah)



## CHARACTERISTICS

Item	Specifications	
Nominal Voltage	12V	
Nominal Capacity (20HR)	90Ah	
Reserve Capacity	158min	
Cold Cranking Amps@0°F (-18°C)	700A	
Dimension	Length	329mm (13.0inches)
	Width	171mm (6.73inches)
	Container Height	215.5mm (8.48inches)
	Total Height (with Terminal)	237mm (9.33inches)
Approx Weight	23.0kg (50.7lbs)	
Terminal	12	
Cell layout	1	
Hold-Down	B0	
Case	Black-PP Material	
Cover	Black-PP Material	
Handle	TS9	

## APPLICATIONS

- Car start
- EV/HEV
- Engine start

## GENERAL FEATURES

- High capacity and high CCA
- Long life
- Advanced lead-calcium alloy technology, maintenance-free design
- Patented venting system bring less water loss and prevent acid leakage
- OE quality certification

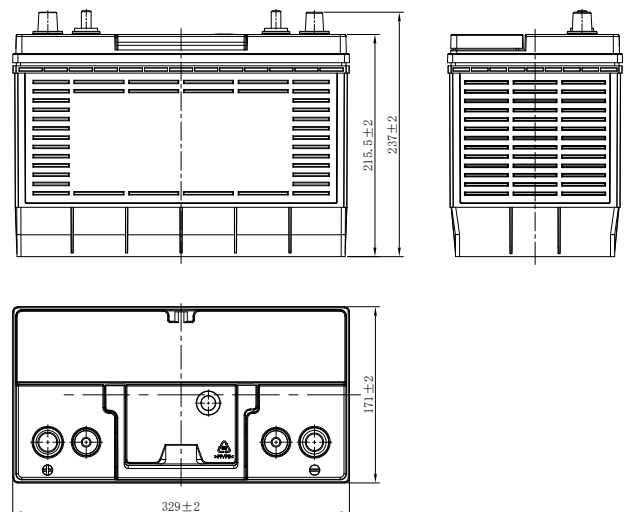
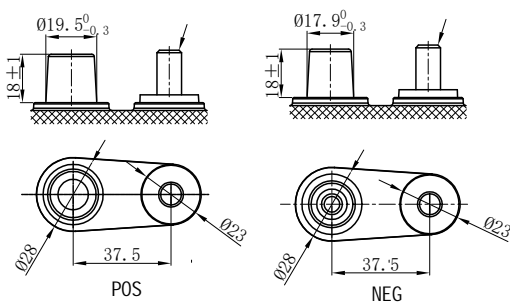

\*Values are subject to variation of +/- 5% in normal manufacturing processes.

Leoch International Technology Ltd.  
www.leoch.com

Leoch Batteries Pte Ltd  
www.leoch.sg

Leoch Battery Corporation  
www.leochamericas.com

Leoch Europe S.A.  
www.leoch.eu