

# FLOODED BATTERY

78-520 (12V60Ah)



## CHARACTERISTICS

Item	Specifications	
Nominal Voltage	12V	
Nominal Capacity (20HR)	60Ah	
Reserve Capacity	98min	
Cold Cranking Amps@0°F (-18°C)	520A	
Dimension	Length	268mm (10.6inches)
	Width	180mm (7.09inches)
	Container Height	182mm (7.17inches)
	Total Height (with Terminal)	182mm (7.17inches)
Approx Weight	15.7kg (34.6lbs)	
Terminal	20	
Cell layout	6	
Hold-Down	B01	
Case	Black-PP Material	
Cover	Black-PP Material	
Handle	TS5	

## APPLICATIONS

- Car start
- EV/HEV
- Engine start

## GENERAL FEATURES

- High capacity and high CCA
- Long life
- Advanced lead-calcium alloy technology, maintenance-free design
- Patented venting system bring less water loss and prevent acid leakage
- OE quality certification

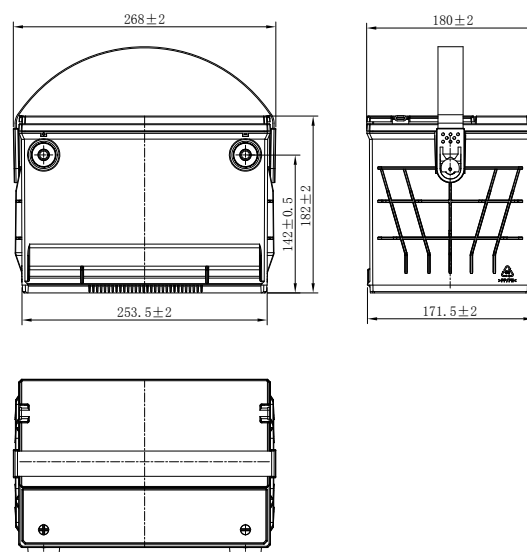
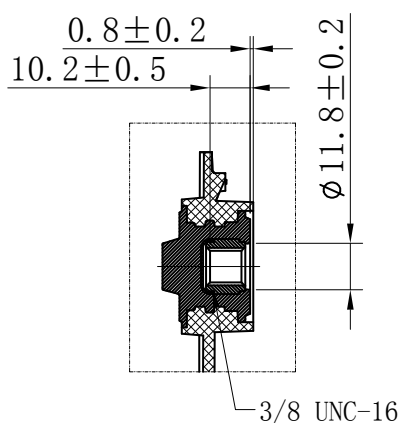

\*Values are subject to variation of +/- 5% in normal manufacturing processes.

Leoch International Technology Ltd.  
www.leoch.com

Leoch Batteries Pte Ltd  
www.leoch.sg

Leoch Battery Corporation  
www.leochamericas.com

Leoch Europe S.A.  
www.leoch.eu