

# FLOODED HIGH TEMPERATURE BATTERY

170G51LHT (12V170Ah)



## CHARACTERISTICS

Item	Specifications	
Nominal Voltage	12V	
Nominal Capacity (20HR)	170Ah	
Reserve Capacity	336min	
Cold Cranking Amps@0°F (-18°C)	1000A	
Dimension	Length	510mm (20.1inches)
	Width	222mm (8.74inches)
	Container Height	196mm (7.72inches)
	Total Height (with Terminal)	217mm (8.54inches)
Approx Weight	42.8kg (94.4lbs)	
Terminal	1	
Cell layout	4	
Hold-Down	B0	
Case	Black-PP Material	
Cover	Black-PP Material	
Handle	TS8	

## APPLICATIONS

- Car start
- EV/HEV
- Engine start

## GENERAL FEATURES

- Design for high temperature countries and regions
- Superior life in high temperature environment
- High tin alloy and thicker positive grid
- High-temp paste
- Patented venting system bring less water loss and prevent acid leakage

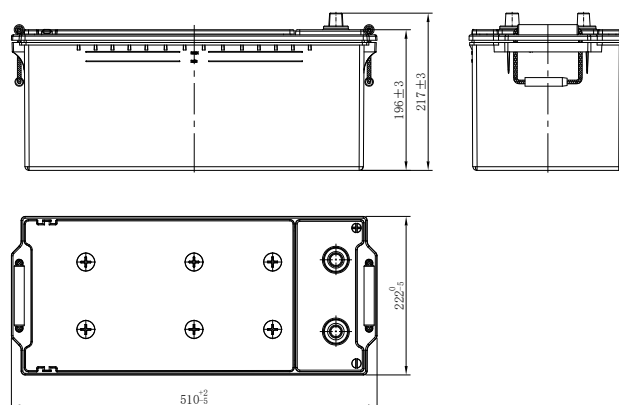
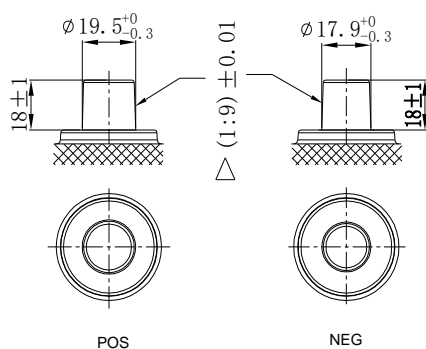

\*Values are subject to variation of +/- 5% in normal manufacturing processes.

Leoch International Technology Ltd.  
[www.leoch.com](http://www.leoch.com)

Leoch Batteries Pte Ltd  
[www.leoch.sg](http://www.leoch.sg)

Leoch Battery Corporation  
[www.leochamericas.com](http://www.leochamericas.com)

Leoch Europe S.A.  
[www.leoch.eu](http://www.leoch.eu)