

FLOODED HIGH TEMPERATURE BATTERY

55025HT (12V49Ah)



CHARACTERISTICS

| Item | Specifications | |
|--------------------------------|------------------------------|--------------------|
| Nominal Voltage | 12V | |
| Nominal Capacity (20HR) | 49Ah | |
| Reserve Capacity | 77min | |
| Cold Cranking Amps@0°F (-18°C) | 380A | |
| Dimension | Length | 207mm (8.15inches) |
| | Width | 175mm (6.89inches) |
| | Container Height | 190mm (7.48inches) |
| | Total Height (with Terminal) | 190mm (7.48inches) |
| Approx Weight | 12.5kg (27.6lbs) | |
| Terminal | 1 | |
| Cell layout | 0 | |
| Hold-Down | B13 | |
| Case | Black-PP Material | |
| Cover | Black-PP Material | |
| Handle | TS2 | |

APPLICATIONS

- Car start
- EV/HEV
- Engine start

GENERAL FEATURES

- Design for high temperature countries and regions
- Superior life in high temperature environment
- High tin alloy and thicker positive grid
- High-temp paste
- Patented venting system bring less water loss and prevent acid leakage

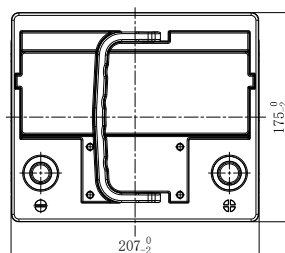
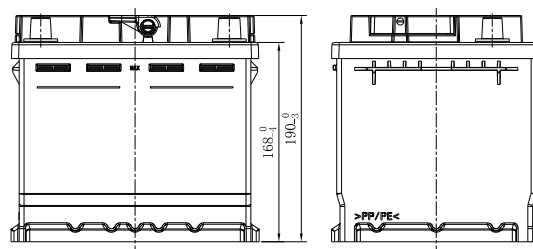
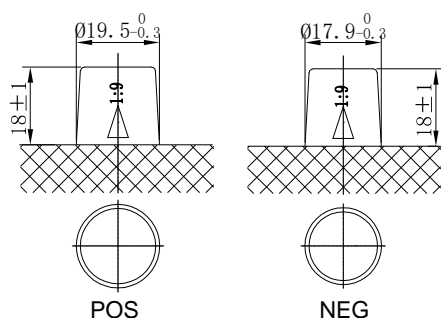

*Values are subject to variation of +/- 5% in normal manufacturing processes.

Leoch International Technology Ltd.
www.leoch.com

Leoch Batteries Pte Ltd
www.leoch.sg

Leoch Battery Corporation
www.leochamericas.com

Leoch Europe S.A.
www.leoch.eu