

HEAVY DUTY FLOODED BATTERY

105F51L (12V110Ah)



CHARACTERISTICS

Item	Specifications	
Nominal Voltage	12V	
Nominal Capacity (20HR)	110Ah	
Reserve Capacity	201min	
Cold Cranking Amps@0°F (-18°C)	750A	
Dimension	Length	504mm (19.8inches)
	Width	183.5mm (7.22inches)
	Height	223mm (8.78inches)
Approx Weight	32.0kg (70.5lbs)	
Terminal	1	
Cell layout	4	
Hold-Down	B0	
Case	Black-PP Material	
Cover	Black-PP Material	
Handle	TS8	

APPLICATIONS

- Commercial vehicle start
- Engine start

GENERAL FEATURES

- High capacity and high CCA
- Maintenance-free
- High vibration resistance
- Strong lead-calcium alloy grids for great corrosion resistance
- High strength PP case and cover no need be worried about breakage
- OE quality certification

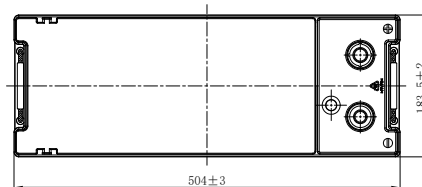
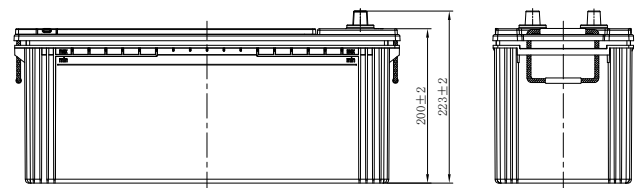
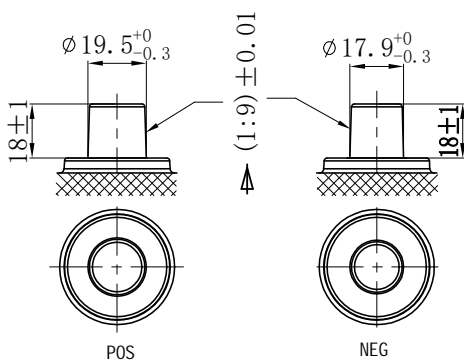

*Values are subject to variation of +/- 5% in normal manufacturing processes.

Leoch International Technology Ltd.
www.leoch.com

Leoch Batteries Pte Ltd
www.leoch.sg

Leoch Battery Corporation
www.leochamericas.com

Leoch Europe S.A.
www.leoch.eu