

FLOODED HIGH TEMPERATURE BATTERY

46B24RHT (12V45Ah)



CHARACTERISTICS

| Item | Specifications | |
|--------------------------------|-------------------|-------------------|
| Nominal Voltage | 12V | |
| Nominal Capacity (20HR) | 45Ah | |
| Reserve Capacity | 70min | |
| Cold Cranking Amps@0°F (-18°C) | 350A | |
| Dimension | Length | 236mm(9.29inches) |
| | Width | 128mm(5.04inches) |
| | Height | 222mm(8.74inches) |
| Approx Weight | 11.7kg(25.8lbs) | |
| Terminal | 3 | |
| Cell layout | 1 | |
| Hold-Down | B0 | |
| Case | Black-PP Material | |
| Cover | Black-PP Material | |
| Handle | TS1 | |

APPLICATIONS

- Car start
- EV/HEV
- Engine start

GENERAL FEATURES

- Design for high temperature countries and regions
- Superior life in high temperature environment
- High tin alloy and thicker positive grid
- High-temp paste
- Patented venting system bring less water loss and prevent acid leakage

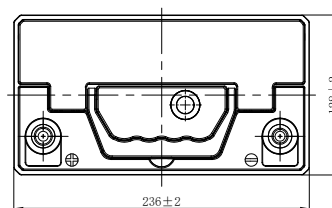
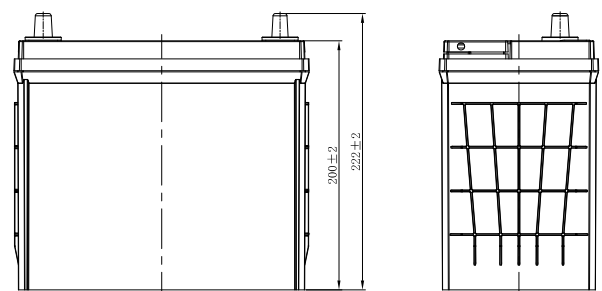
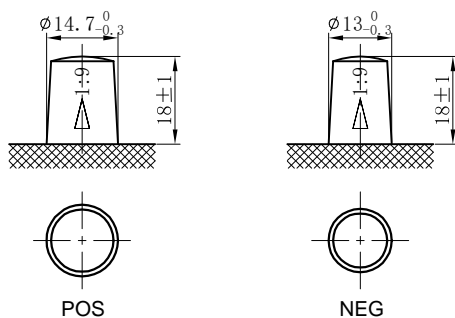

*Values are subject to variation of +/- 5% in normal manufacturing processes.

Leoch International Technology Ltd.
www.leoch.com

Leoch Batteries Pte Ltd
www.leoch.sg

Leoch Battery Corporation
www.leochamericas.com

Leoch Europe S.A.
www.leoch.eu

Data above is recommended and the picture is only for battery effect display, Leoch reserve the final right of explanation.
© LEOCH. All rights reserved. Trademarks and logos are the property of LEOCH and its affiliates unless otherwise noted. Subject to revisions without prior notice. E&OE.

Publication No.: LB-46B24RHT-PD-EN-V1.0-20250220