

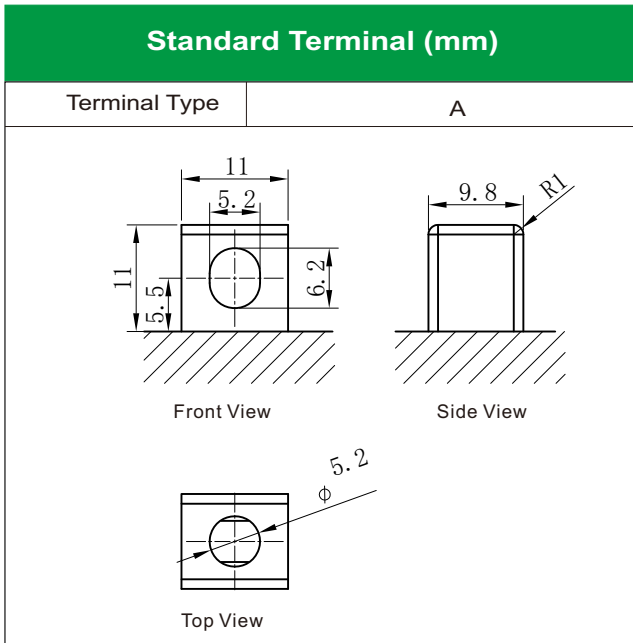

LEOCH BATTERY

# HPG4-3-2 [12V3Ah]

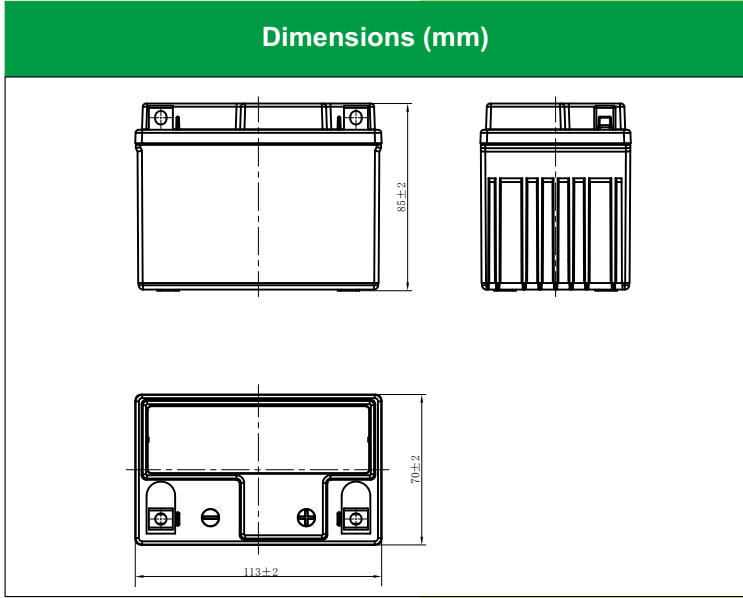
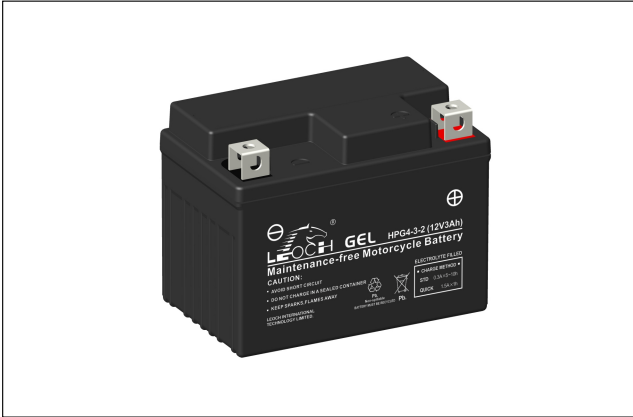

### Physical Specification

Nominal Voltage		12V
Nominal Capacity (10HR)		3Ah
Dimension	Length	113±2mm (4.45 inches)
	Width	70±2mm (2.76 inches)
	Container Height	85±2mm (3.35 inches)
	Total Height (with Terminal)	85±2mm (3.35 inches)
Weight	Battery(with acid): Approx 1.36kg (3.0lbs)	
	Electrolyte: Approx 0.24kg (0.53lbs)	

- \* 100% leak-proof and spill-proof to 360°
- \* Totally Maintenance-free
- \* Longer lifespan
- \* Lower self discharge
- \* Powerful 50 cold cranking amps
- \* Shipped pre-charged and ready to install
- \* Replaces LT4-3-2 battery

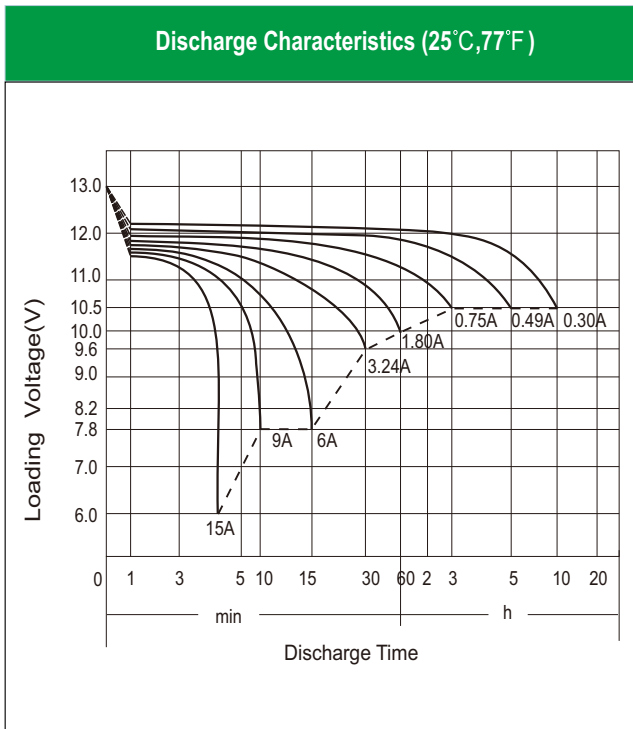

### Electrical Specification

Rated Capacity	10 hour rate (0.30 A)	3.00Ah
	5 hour rate (0.49 A)	2.46Ah
	2 hour rate (1.05 A)	2.10Ah
	1 hour rate (1.80 A)	1.80Ah
	0.5 hour rate (3.24 A)	1.62Ah
Capacity affected by Temperature	40 °C (104 °F)	106%
	25 °C (77 °F)	100%
	0 °C (32 °F)	86%
	-15 °C (5 °F)	65%
Charging Methods	Full Charge	Constant-Voltage Charge: Initial charging current: less than 0.9A Voltage: 14.40 V ~ 15.00 V at 25 °C (77 °F) Charging time: 15 ~18h Constant-Current Charge: Charging current: 0.1C <sub>10</sub> =0.3A, when charging voltage up to 14.40V, continue to charge 4h
	Floating Charge	No limit on Initial charging current Voltage: 13.50 V ~ 13.80 V at 25 °C (77 °F)

\*Values are subject to variation of +/- 5% in normal manufacturing processes.  
 \*Technical specifications and the product line above could be changed without prior notice.