

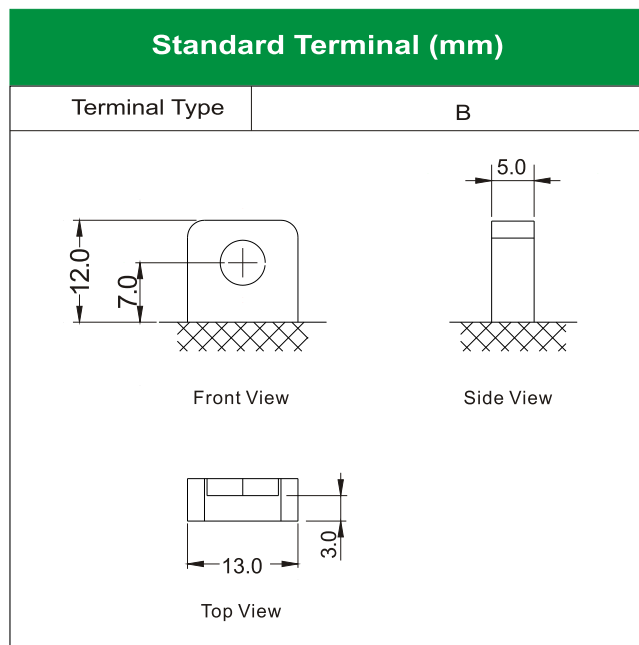

LEOCH BATTERY

# HPG6.5-3 [12V6.5Ah]

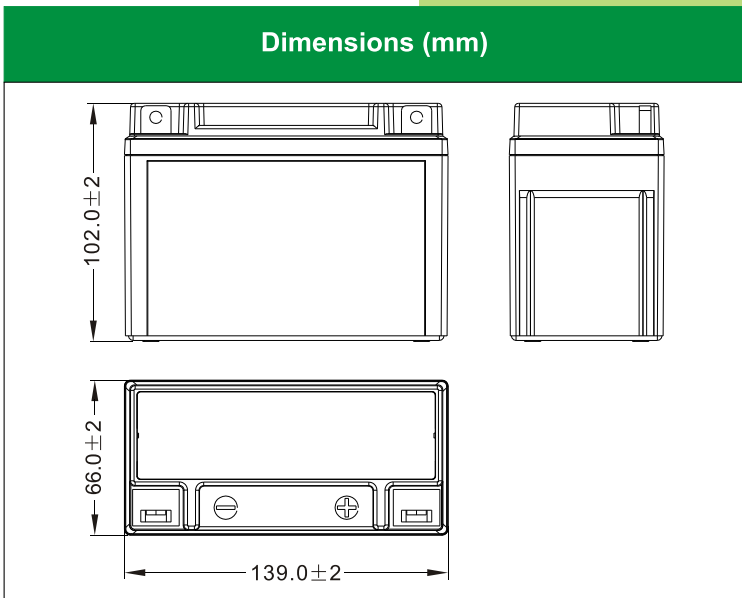

### Physical Specification

Nominal Voltage	12V	
Nominal Capacity (10HR)	6.5Ah	
Dimension	Length	139 ± 2mm (5.47 inches)
	Width	66 ± 2mm (2.60 inches)
	Container Height	102 ± 2mm (4.02 inches)
	Total Height (with Terminal)	102 ± 2mm (4.02 inches)
Weight	Battery(with acid): Approx 2.30kg (5.07lbs)	
	Electrolyte: Approx 0.40kg (0.88lbs)	

- \* 100% leak-proof and spill-proof to 360°
- \* Totally Maintenance-free
- \* Longer lifespan
- \* Lower self discharge
- \* Powerful 85 cold cranking amps
- \* Shipped pre-charged and ready to install
- \* Replaces LT6.5-3 battery

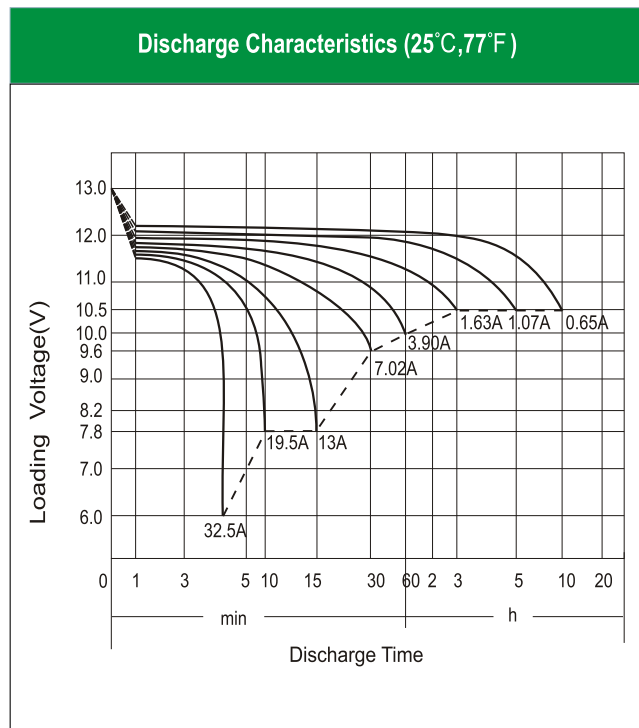

### Electrical Specification

Rated Capacity	10 hour rate (0.65A)	6.50Ah
	5 hour rate (1.07 A)	5.33Ah
	2 hour rate (2.28 A)	4.55Ah
	1 hour rate (3.90 A)	3.90Ah
	0.5 hour rate (7.02 A)	3.51Ah
Capacity affected by Temperature	40 °C (104 °F)	106%
	25 °C (77 °F)	100%
	0 °C (32 °F)	86%
	-15 °C (5 °F)	65%
Charging Methods	Full Charge	Constant-Voltage Charge: Initial charging current: less than 1.95A Voltage: 14.40 V ~ 15.00 V at 25 °C (77 °F) Charging time: 15 ~18h Constant-Current Charge: Charging current: 0.1C <sub>10</sub> =0.65A, when charging voltage up to 14.40V, continue to charge 4h
	Floating Charge	No limit on Initial charging current Voltage: 13.50 V ~ 13.80 V at 25 °C (77 °F)