

Physical Specification

Nominal Voltage		12.8V
Nominal Capacity		3.0Ah
Dimension	Length	150 ± 2mm (5.91 inches)
	Width	87 ± 2mm (3.43 inches)
	Container Height	105 ± 2mm (4.13 inches)
	Total Height (with Terminal)	105 ± 2mm (4.13 inches)
Weight	Approx 0.67kg (1.48lbs)	

- * Motorcycle Li-ion battery
- * Powerful cranking amps
- * Shipped pre-charged and ready to install
- * Built in BMS to monitor the battery status in real time and protect the battery
- * Replaces YTX9-BS/YTR9-BS battery

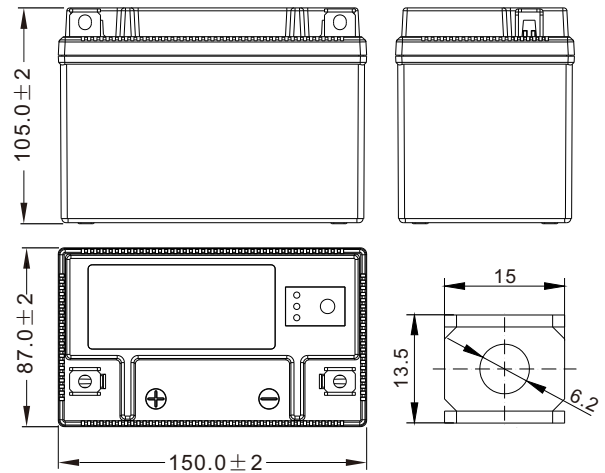

Dimensions (mm)

Electrical Specification

Rated Capacity	0.1C rate (0.3A)	3.0Ah
	0.5C rate (1.5A)	3.0Ah
	10C rate (30.0A)	2.7Ah
	70C rate (0.0A)	3HDN&XUUHQW
Capacity affected by Temperature	40 °C (104 °F)	98%
	25 °C (77 °F)	100%
	0 °C (32 °F)	85%
	-20 °C (-4 °F)	60%
Self Discharge	Approximately 1.5% per month (25°C (77°F))	
Charging Methods	Constant-Voltage Charge:	
	Full Charge	Initial charging current: less than 1.5A Voltage: 14.40 V ~ 14.60 V at 25 °C (77 °F)

Curve Specification

