

# CONVENTIONAL FLOODED MOTORCYCLE BATTERY

LB10L-B(J) (12V11Ah)

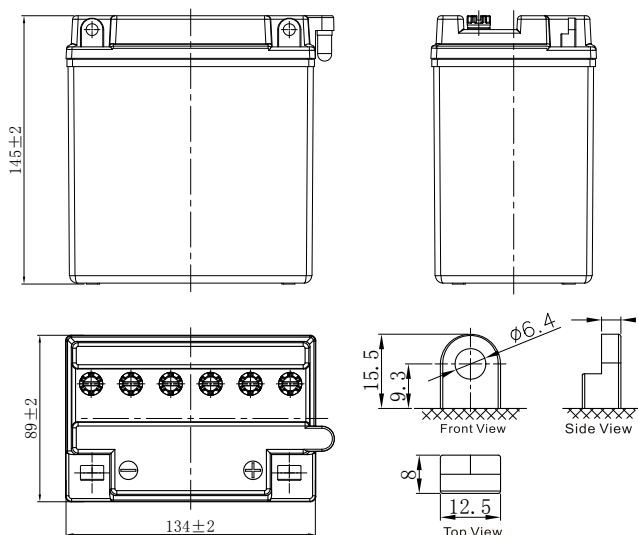

## GENERAL FEATURES

- Low maintenance
- High performance and dry charged high quality and flooded battery
- Shipped without battery electrolyte pre-charged and ready to install

\*Values are subject to variation of +/- 5% in normal manufacturing processes.

Leoch International Technology Ltd.  
www.leoch.com

Leoch Batteries Pte Ltd  
www.leoch.sg

Leoch Battery Corporation  
www.leochamericas.com

Leoch Europe S.A.  
www.leoch.eu

## CHARACTERISTICS

Item	Specifications	
Nominal Voltage	12V	
Nominal Capacity (10HR)	11Ah	
Cold Cranking Performance Amps@0°F (-18°C)	100A	
Dimension (±2mm)	Length	134mm (5.28inches)
	Width	89mm (3.50inches)
	Container Height	145mm (5.71inches)
	Total Height	145mm (5.71inches)
Battery (with acid)	Approx Weight	3.65kg (8.05lbs)
Electrolyte	Approx Weight	1.02kg (2.25lbs)
Terminal type	B	
Battery type	Conventional Flooded (High Performance) Series	
Constant-Voltage Charge:		
Initial charging current	Less than 0.3C <sub>10</sub>	
Voltage	14.40V~15.00V at 25°C (77°F)	
Charging time	16~24h	
Constant-Current Charge:		
Charging current 0.1C <sub>10</sub> , when charging voltage up to 15.60V, continue to charge 2h		
Floating Charge	Initial charging current	Unlimited
	Voltage	13.50V~13.80V at 25°C (77°F)
Capacity affected by Temperature	40°C (104°F)	106%
	25°C (77°F)	100%
	0°C (32°F)	86%
	-15°C (5°F)	65%

## Discharge Characteristics (25°C, 77°F)

