

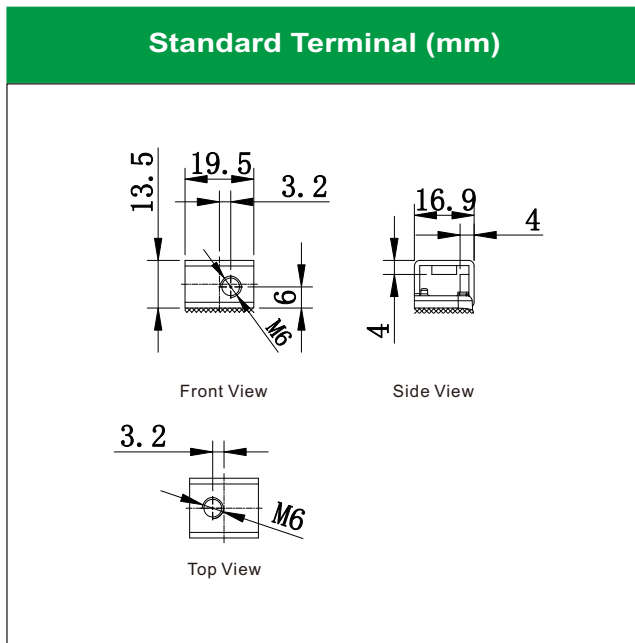

LEOCH BATTERY MX20-4-3 [12V18Ah]

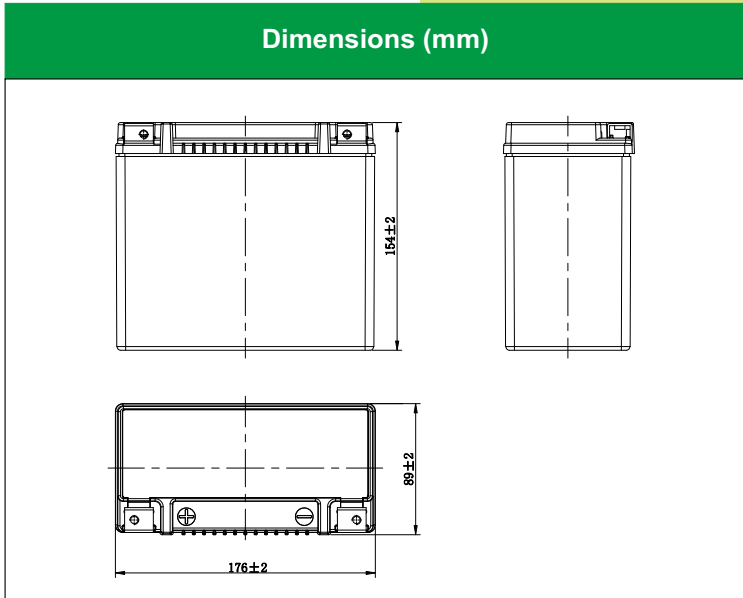

Physical Specification

Nominal Voltage		12V
Nominal Capacity (10HR)		18Ah
Dimension	Length	176±2mm (6.93 inches)
	Width	89±2mm (3.50 inches)
	Container Height	154±2mm (6.06 inches)
	Total Height (with Terminal)	154±2mm (6.06 inches)
Weight	Battery(with acid): Approx 6.55kg (14.44lbs)	
	Electrolyte: Approx 1.1kg (2.43lbs)	

- * Sealed and non-spillable AGM battery
- * Maintenance-free
- * Powerful 320 cold cranking amps (-18°C, SAE Standard)
- * Shipped pre-charged and ready to install

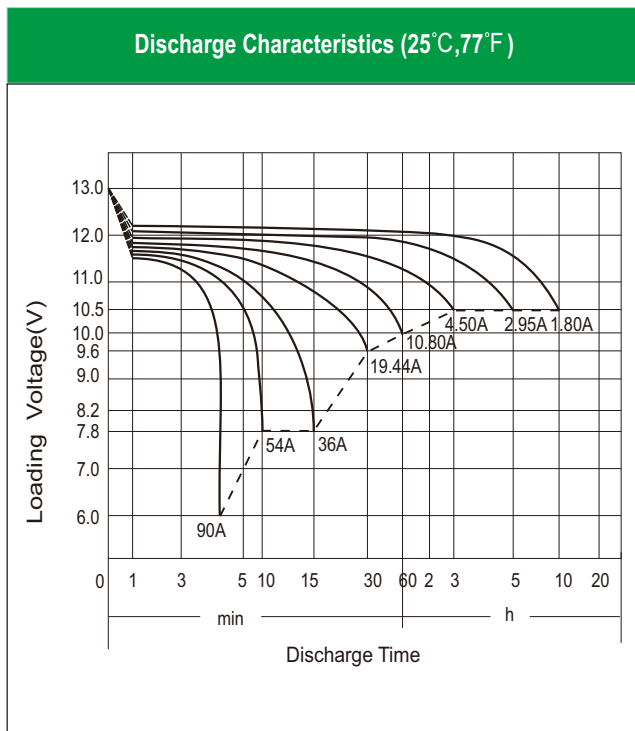

Electrical Specification

Rated Capacity	10 hour rate (1.80 A)	18.00Ah
	5 hour rate (2.95 A)	14.76Ah
	2 hour rate (6.30 A)	12.60Ah
	1 hour rate (10.80 A)	10.80Ah
	0.5 hour rate (19.44 A)	9.72Ah
Capacity affected by Temperature	40 °C (104 °F)	106%
	25 °C (77 °F)	100%
	0 °C (32 °F)	86%
	-15 °C (5 °F)	65%
Charging Methods	Full Charge	Constant-Voltage Charge: Initial charging current: less than 5.4A Voltage: 14.40 V ~ 15.00 V at 25 °C (77 °F) Charging time: 15 ~18h Constant-Current Charge: Charging current: 0.1C ₁₀ =1.8A, when charging voltage up to 14.40V, continue to charge 4h
	Floating Charge	No limit on Initial charging current Voltage: 13.50 V ~ 13.80 V at 25 °C (77 °F)

*Values are subject to variation of +/- 5% in normal manufacturing processes.
*Technical specifications and the product line above could be changed without prior notice.